

COMPARTMENT	VOLUME (CUBIC FEET)
L1	38.74
L2	27.29
L3	36.50
RI	38.74
R2	27.29
R3	36.50
BI	32.00
HOSE BED AREA	94.44

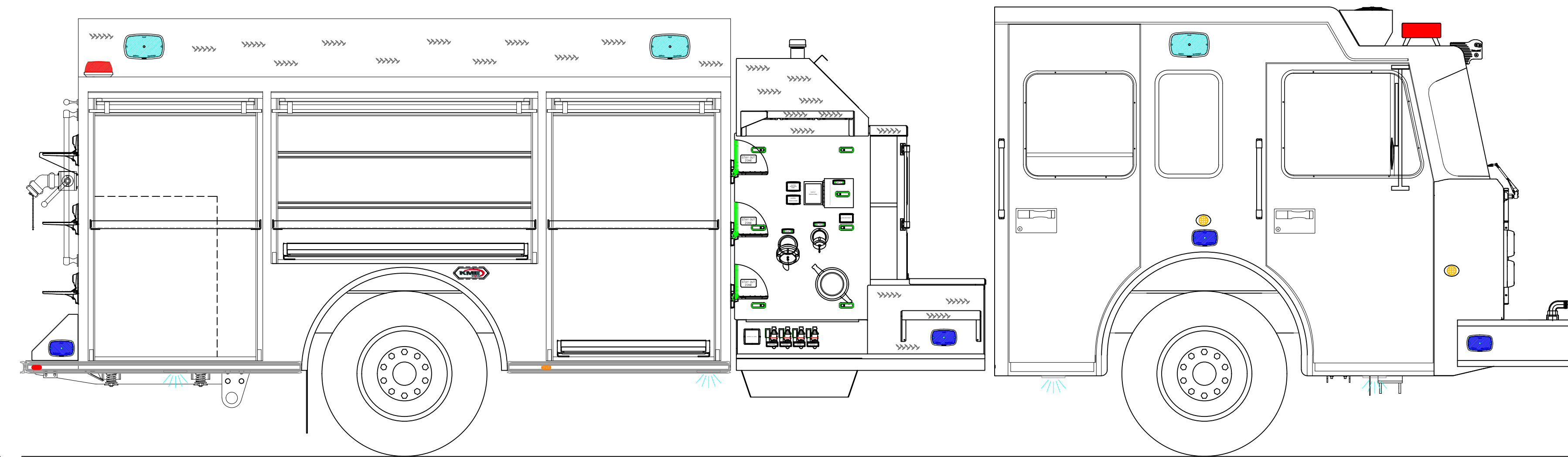
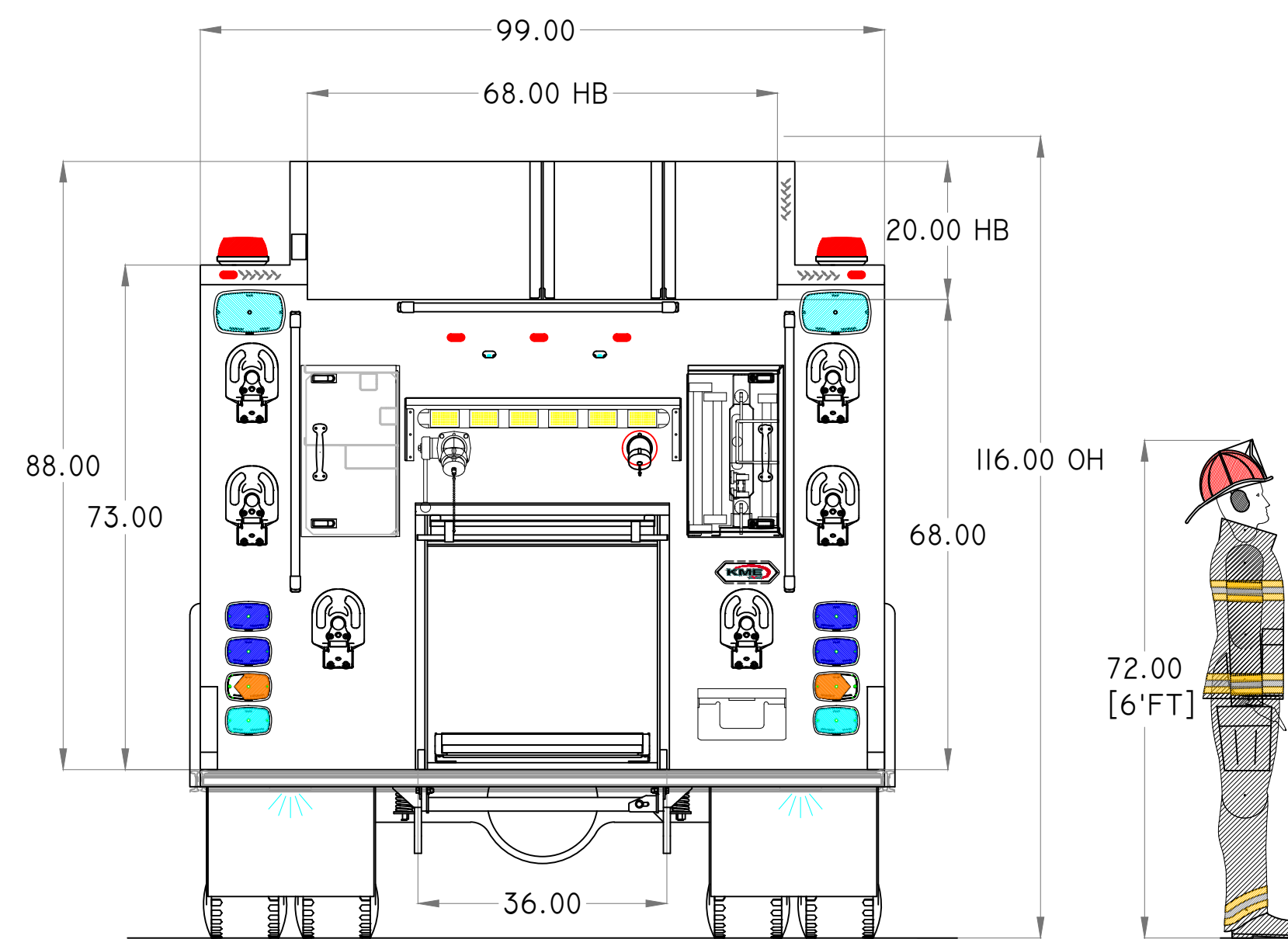
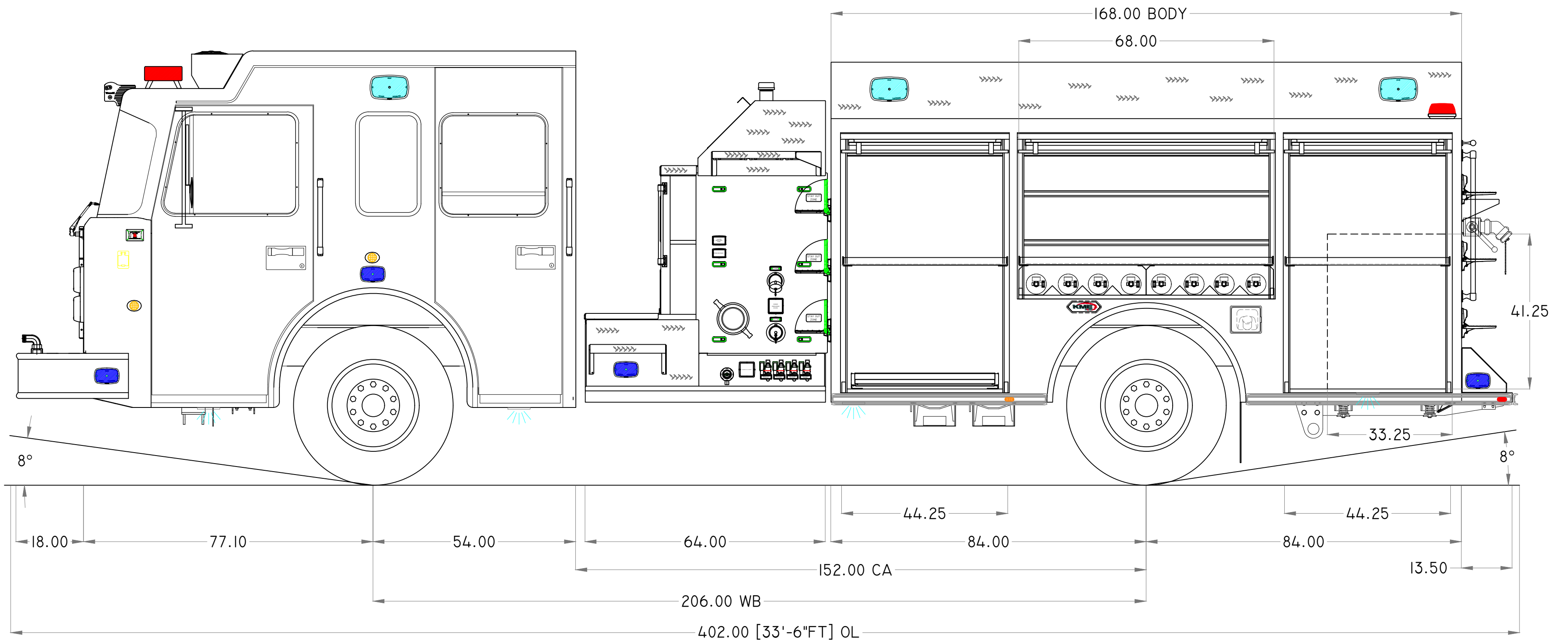
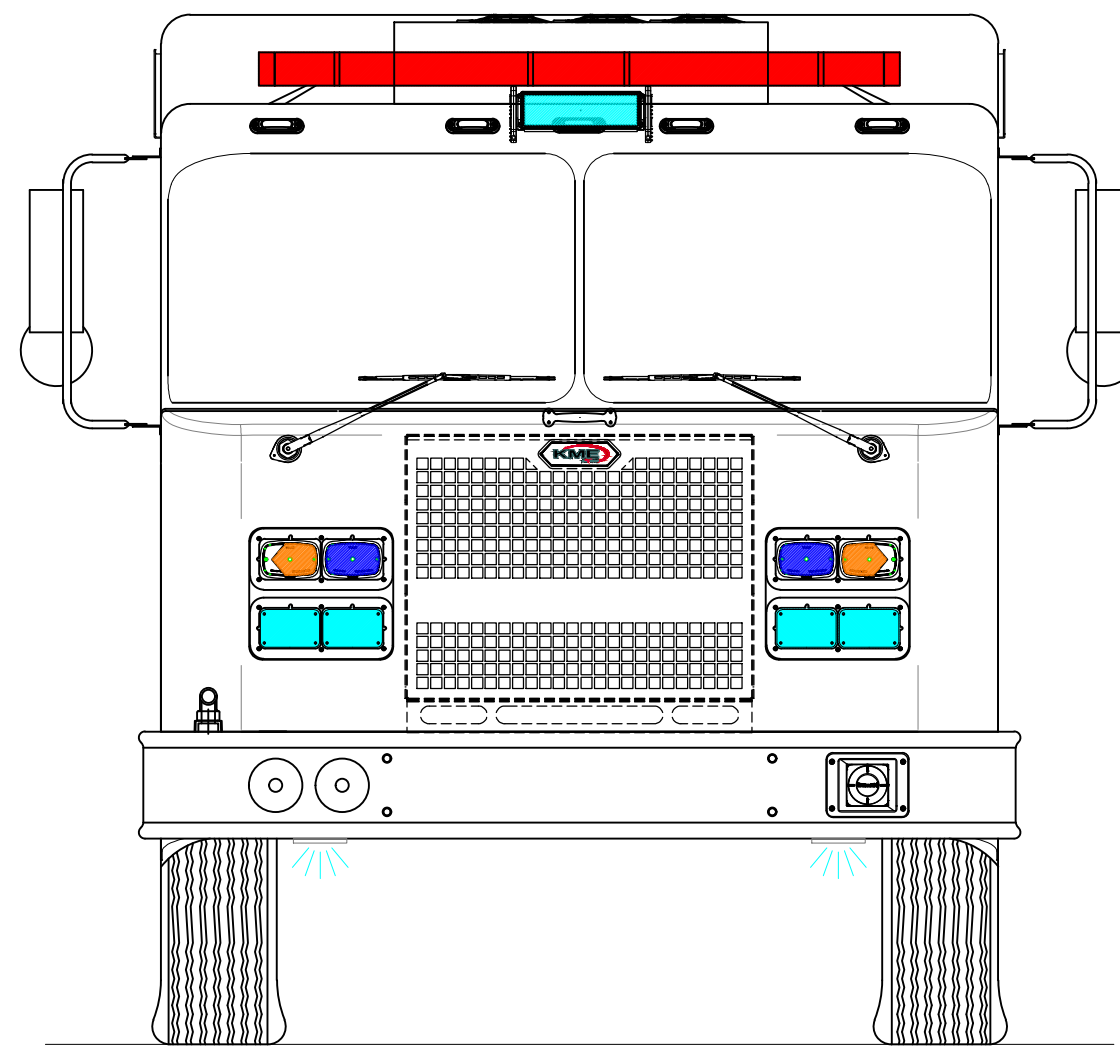
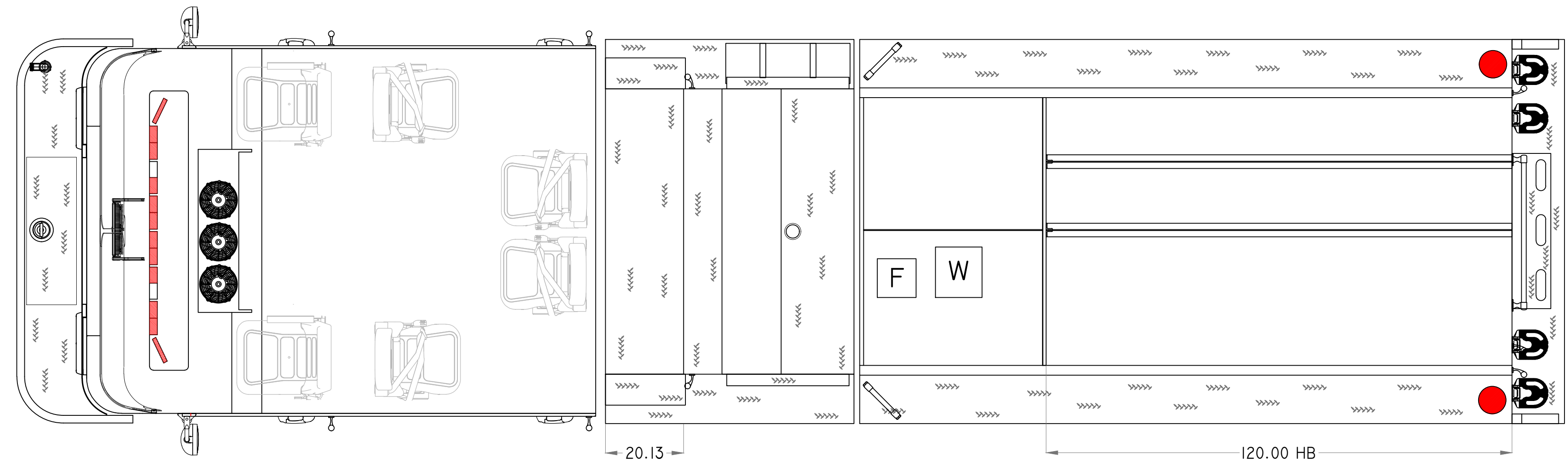

CHASSIS: PANTHER MFD
 AXLES: FRONT 21,500 LB / REAR 27,000 LB
 ENGINE: X12 500 HP / ALLISON 4000 EVS
 BODY: ALUMINUM
 GENERATOR: N/A
 PUMP: WATEROUS CXS 1500 GPM
 TANK: POLY 1000 GAL. WATER/ 20 GAL. FOAM
 FOAM: FOAM-READY

THIS DRAWING IS A GENERAL CONFIGURATION AND MAY NOT NECESSARILY REFLECT ALL CONTRACTUAL REQUIREMENTS. CONTRACT SPECIFICATIONS SHALL PREVAIL OVER DRAWING.

CUSTOMER APPROVAL:

NAME: _____
 TITLE: _____
 DATE: _____

SYM	DATE	REVISION DESCRIPTION	APP'D
A	5/31/2023	PROPOSAL	WMC
SALES ENGINEER :		TBD	



DIMENSIONS ARE APPROXIMATE & MAY VARY DUE TO BUILD ADJUSTMENTS			
SCALE	DWG SIZE	DRAWN BY	DATE
1"=24"	D	WMC	05/31/2023
		APPROVED BY	
MODEL 3111-10			
00000			