

COMPARTMENT	VOLUME (CUBIC FEET)
L1	29.4
L2	27.3
L3	36.5
RI	29.4
R2	27.3
R3	36.5
BI	32.0
HOSE BED AREA	109.7

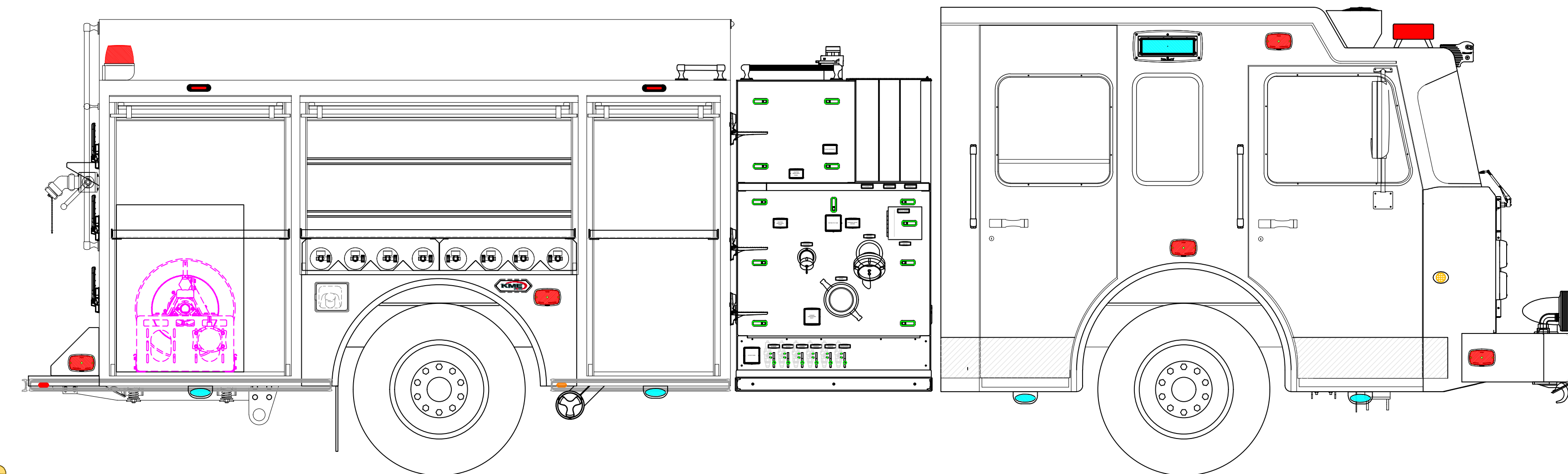
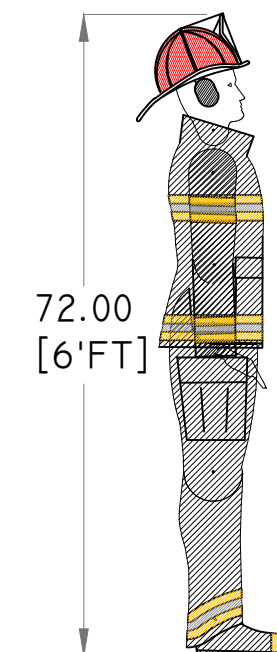
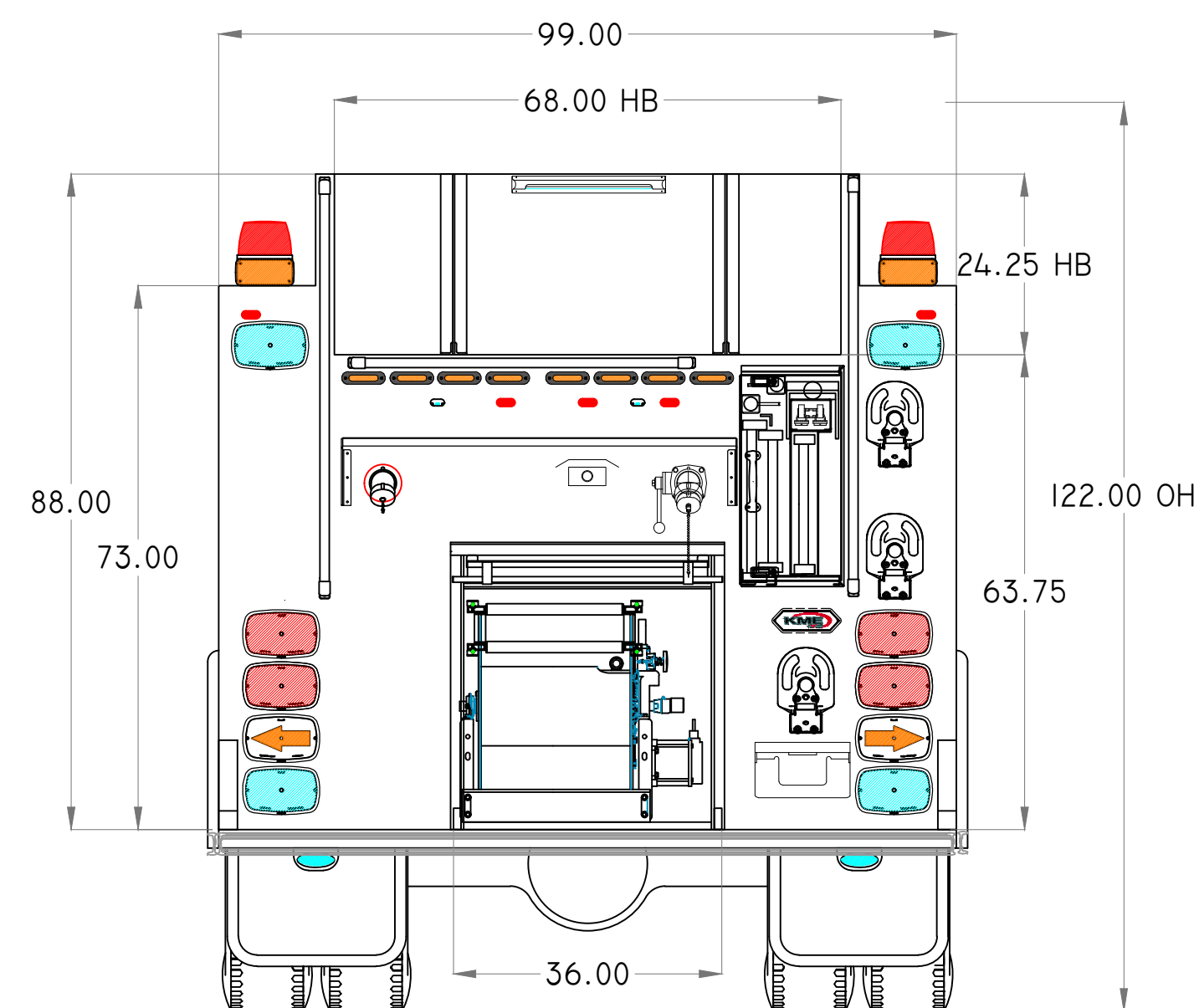
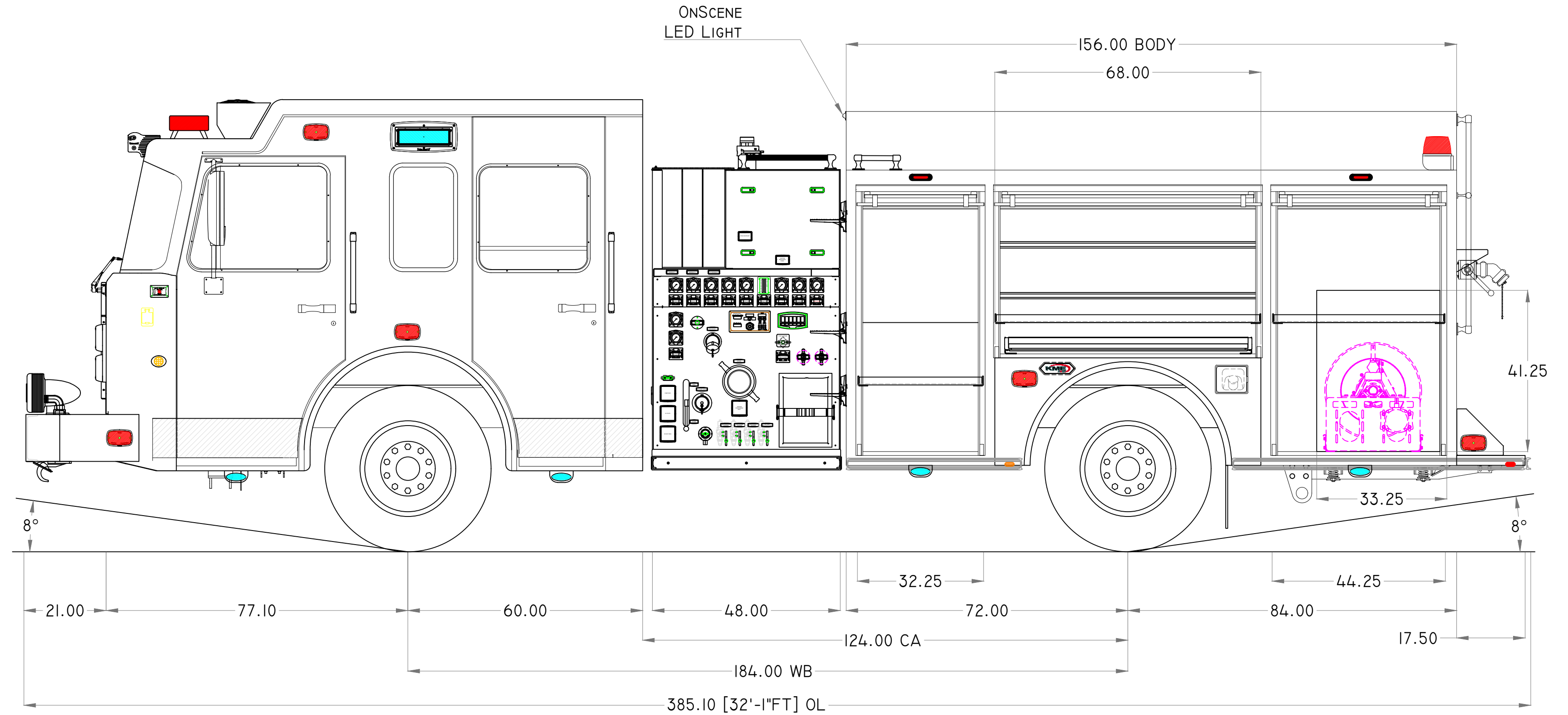
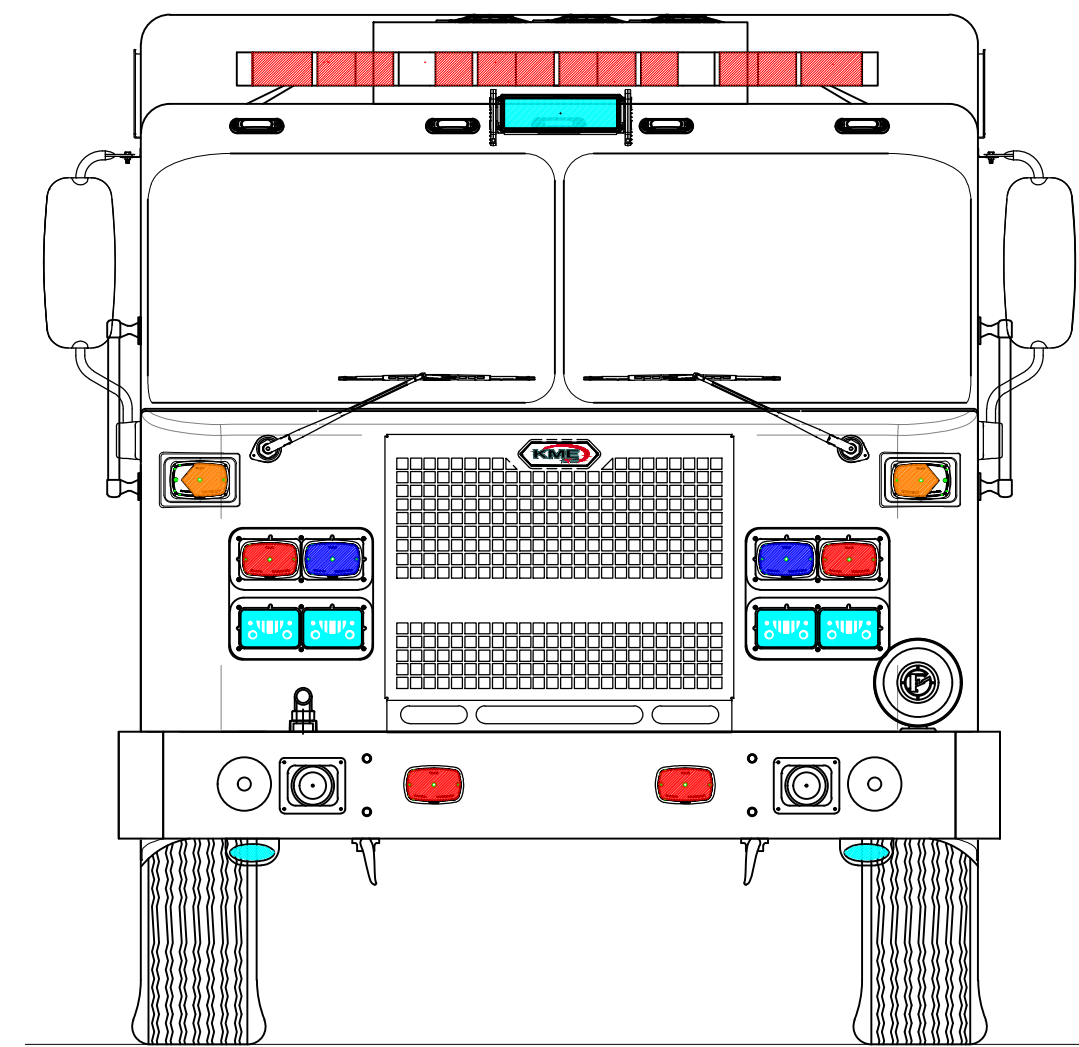
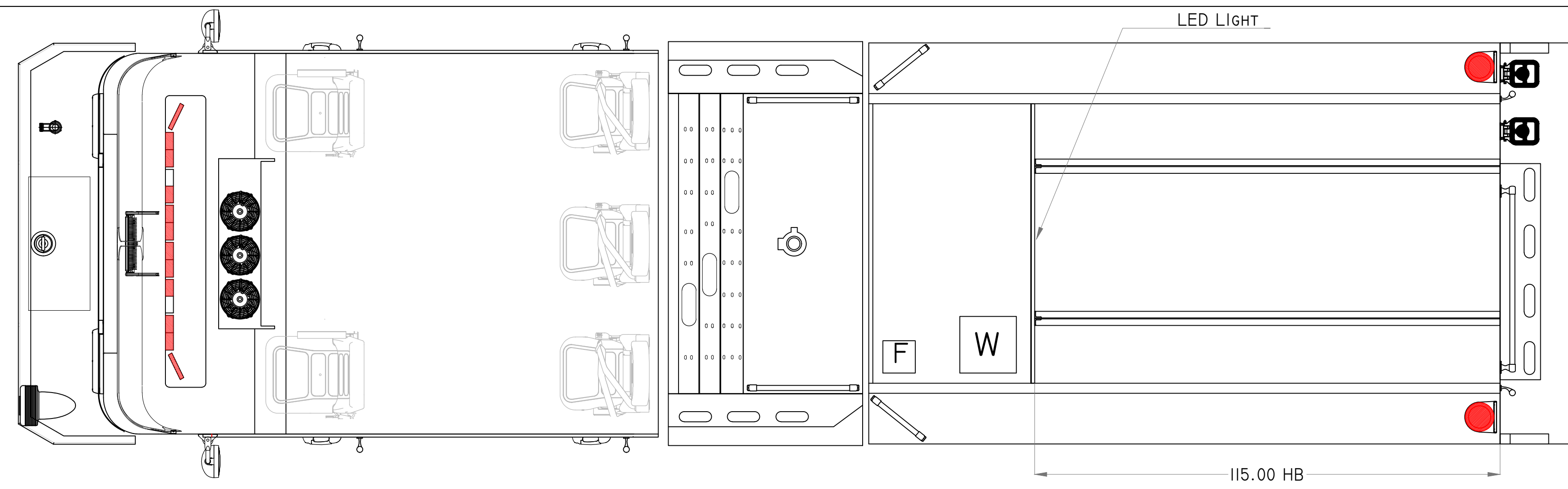

CHASSIS: PANTHER EMFD
 AXLES: FRONT 21,500 LB / REAR 26,000 LB
 ENGINE: CUMMINS X12 500 HP / ALLISON 4000 EVS
 BODY: ALUMINUM
 GENERATOR: N/A
 PUMP: WATEROUS CSU 1500 GPM
 TANK: POLY 1000 GAL. WATER/ 20 GAL. FOAM
 FOAM: FOAM-READY

THIS DRAWING IS A GENERAL CONFIGURATION AND MAY NOT NECESSARILY REFLECT ALL CONTRACTUAL REQUIREMENTS. CONTRACT SPECIFICATIONS SHALL PREVAIL OVER DRAWING.

CUSTOMER APPROVAL:

NAME: _____
 TITLE: _____
 DATE: _____

SYM	DATE	REVISION DESCRIPTION	APP'D
A	5/31/2023	PROPOSAL	WMC
SALES ENGINEER :		TBD	



DIMENSIONS ARE APPROXIMATE & MAY VARY DUE TO BUILD ADJUSTMENTS			
SCALE	DWG SIZE	DRAWN BY	DATE
1"=24"	D	WMC	05/31/2023
		APPROVED BY	

MODEL 3112-10

000000