

COMPARTMENT	VOLUME (CUBIC FEET)
L1	29.4
L2	27.3
L3	36.4
R1	29.4
R2	27.3
R3	36.4
BI	31.9
HOSE BED AREA	150.1

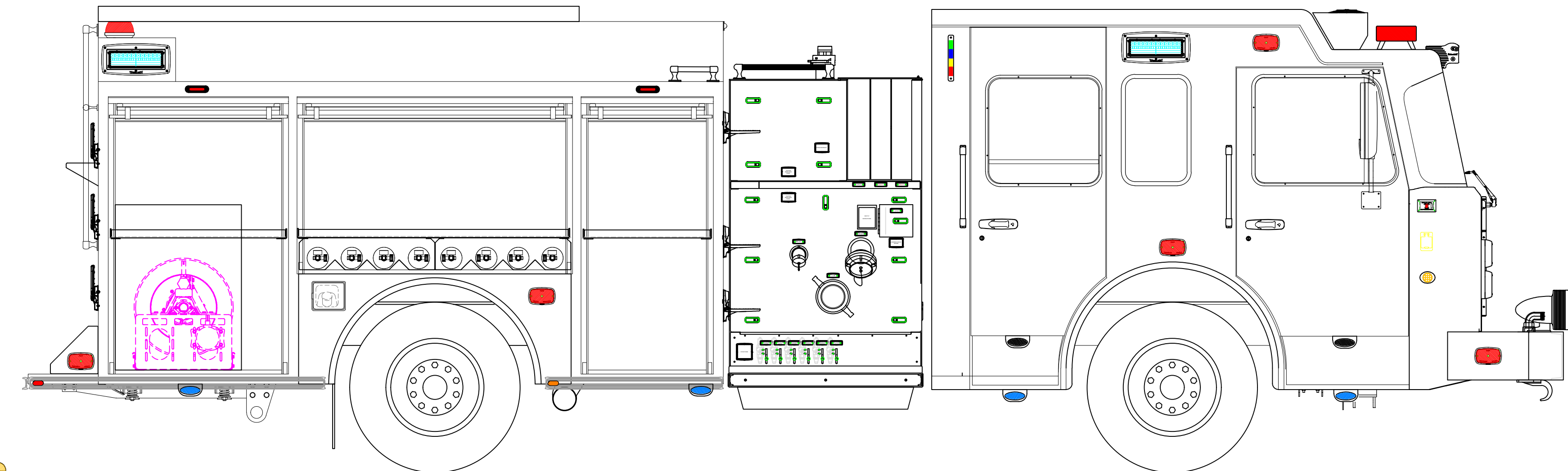
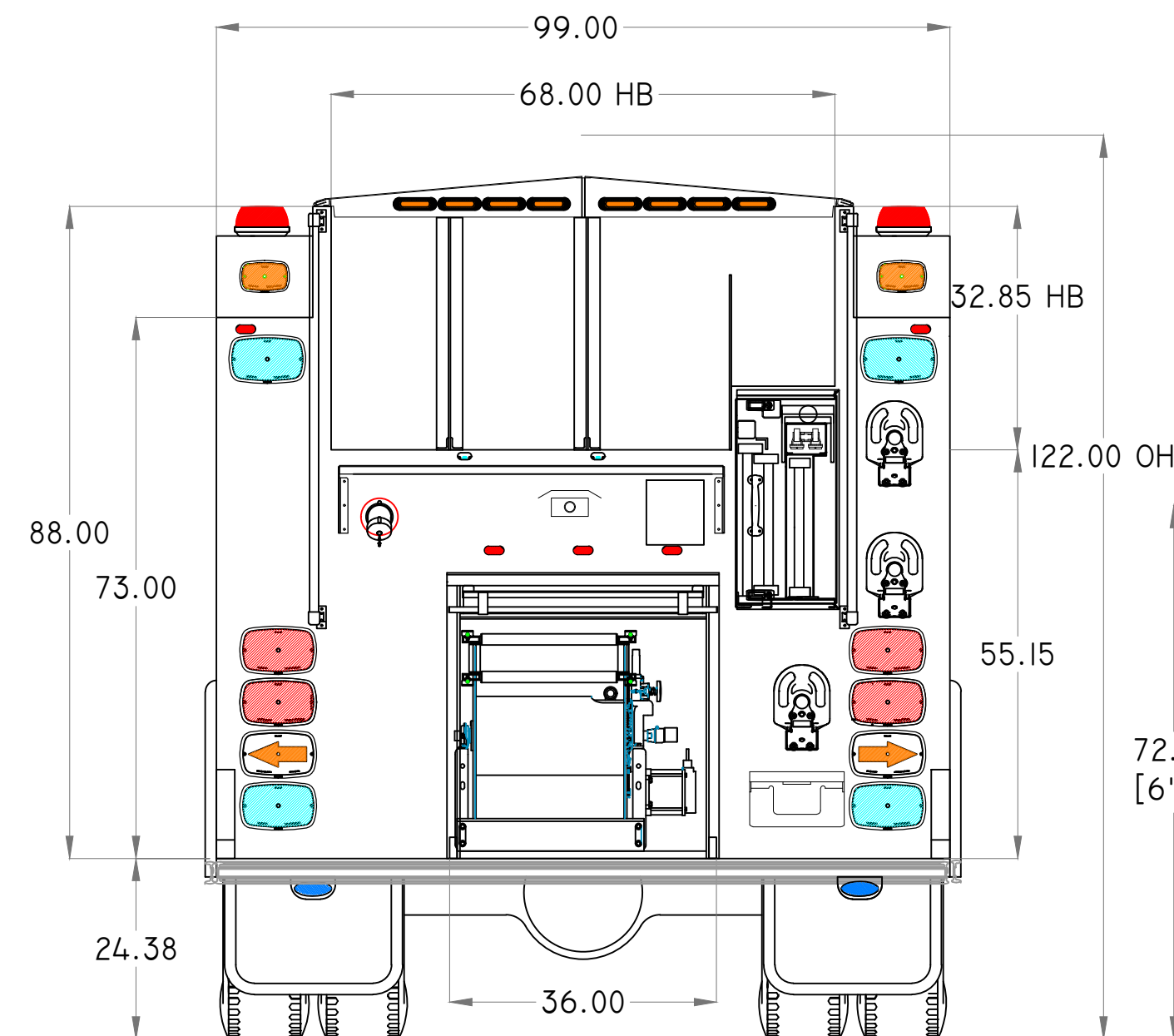
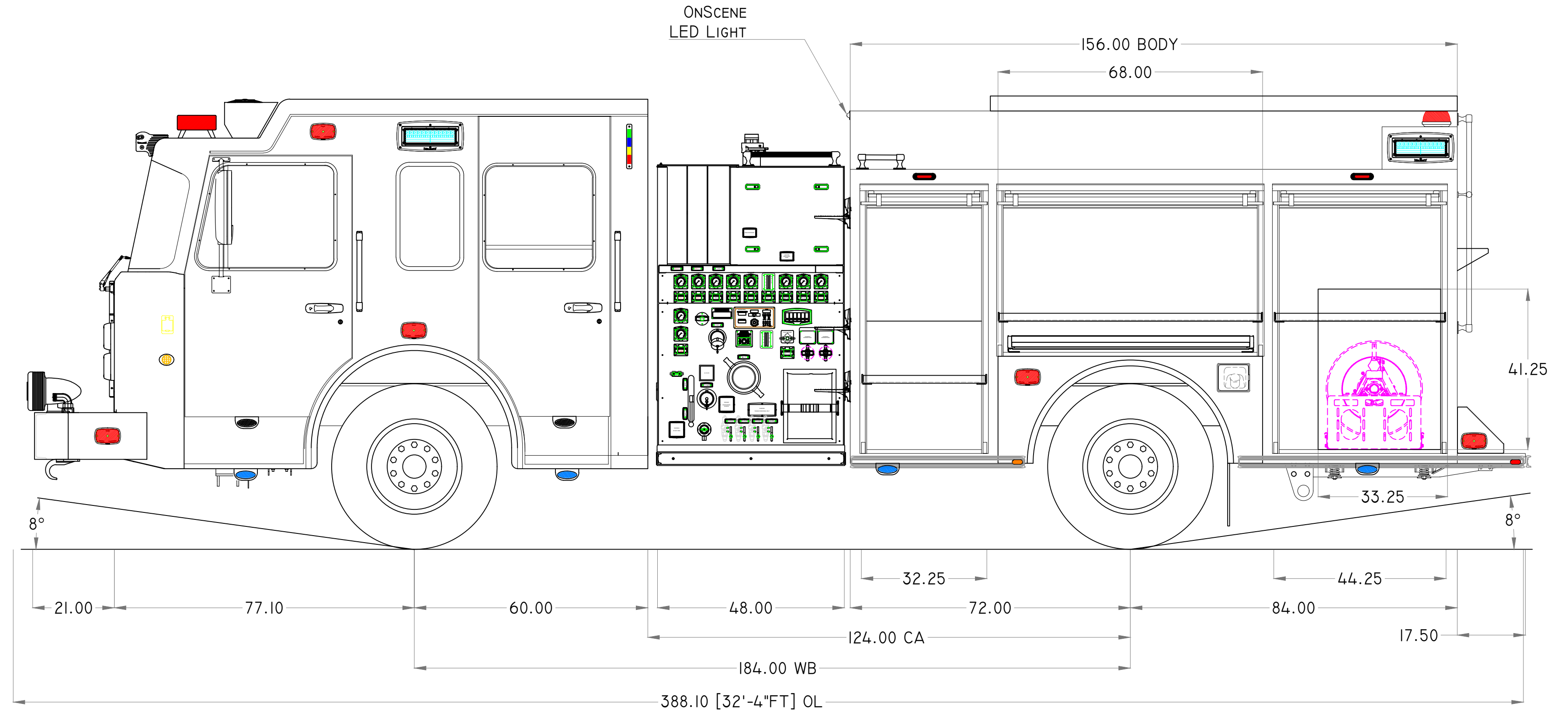
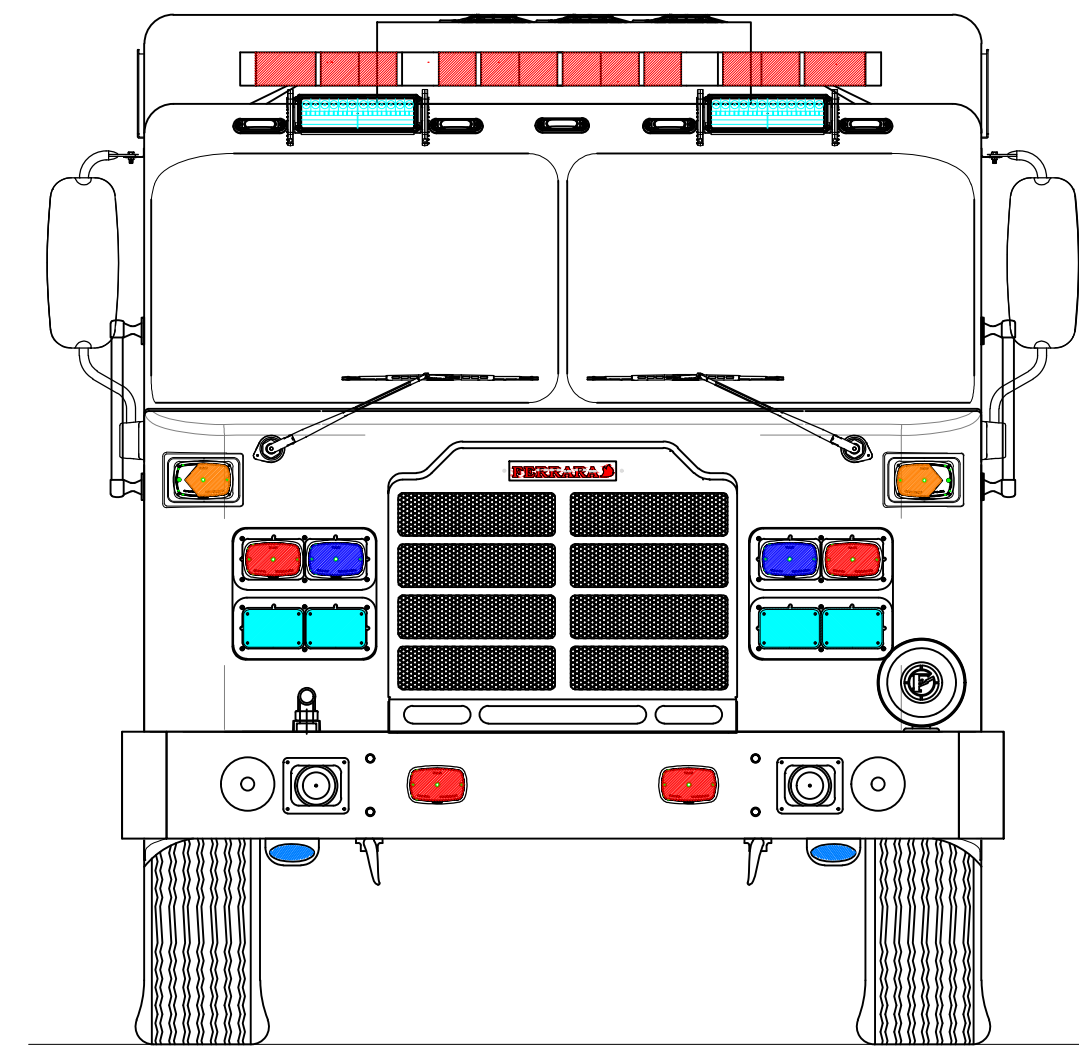
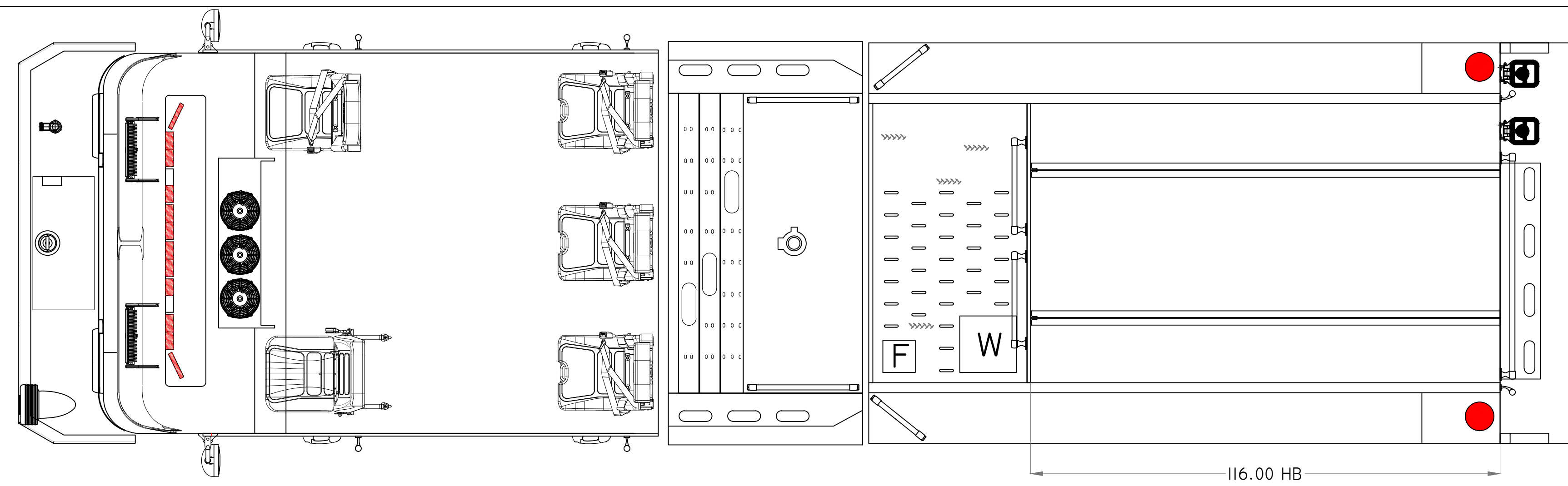

CHASSIS: PANTHER EMFD
 AXLES: FRONT 21,500 LB / REAR 26,000 LB
 ENGINE: CUMMINS ISX12 500 HP/ALLISON 4000 EVS
 BODY: ALUMINUM
 GENERATOR: N/A
 PUMP: WATEROUS CSU 1500 GPM
 TANK: POLY 750 GAL. WATER/ 20 GAL. FOAM
 FOAM: FOAMPRO 1600

THIS DRAWING IS A GENERAL CONFIGURATION AND MAY NOT NECESSARILY REFLECT ALL CONTRACTUAL REQUIREMENTS. CONTRACT SPECIFICATIONS SHALL PREVAIL OVER DRAWING.

CUSTOMER APPROVAL:

NAME: _____
 TITLE: _____
 DATE: _____

SYM	DATE	REVISION DESCRIPTION	APP'D
A	5/8/2023	PROPOSAL	WMC
SALES ENGINEER :		TBD	



DIMENSIONS ARE APPROXIMATE & MAY VARY DUE TO BUILD ADJUSTMENTS			
SCALE	DWG SIZE	DRAWN BY	DATE
1"=24"	D	WMC	05/08/2023

MODEL 3114-10

000000