



SPECIFICATIONS

11048 Severe Service ST Custom Pumper | Retail Unit

CAB/CHASSIS

- KME Severe Service ST 96" Cab with 8" Raised Roof
- Seating for Six (6)
- AXIS Vehicle Monitoring System
- Clean Cab Interior w/HEPA Filter
- LCD Virtual Display
- Hyperion Object Detection with Blind Spot Alert

DRIVE TRAIN

- Cummins X12 455 HP Engine
- Allison 4000 EVS Transmission
- Hendrickson Steertek NXT 24,000 LBS. Front Axle
- Meritor 24,000 LBS. Rear Axle

BODY

- 158" Flushback Body Constructed of 12 GA 3CR12 Stainless Steel
- Amdor Rollup Doors
- 72" Hosebed with Two Adjustable Hosebed Partitions

- Side of Water Tank Ladder/Backboard Storage
- KME Lock N Load Sliding Hose Bed Cover

PUMP/TANK

- Waterous CSU-C20-1500 GPM Single Stage Pump
- 750 Gallon Poly Water Tank with 20 Gallon Foam (A) Cell
- Plumbing for Future Addition of Foam System
- Lowered Crosslays for 200' of 1-3/4" hose

ELECTRICAL

- FRC InView 360° Camera System
- Whelen Warning Light Package and Scene Lights
- HiViz 72" LED Brow Light
- Class-1 ES-Key Multiplex Electrical System

DIMENSIONS

- Overall Height: 120" (100')
- Overall Length: 383" (31'-11")
- Wheelbase: 190"

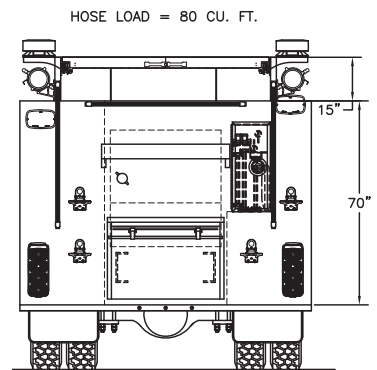
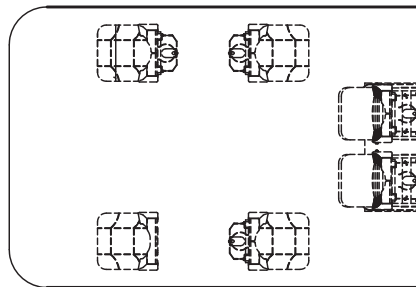
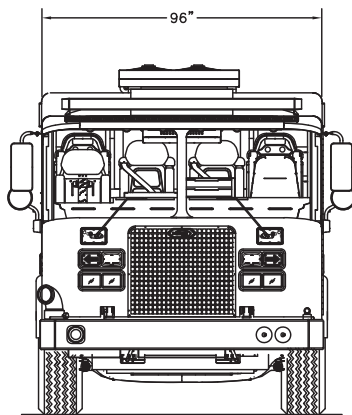
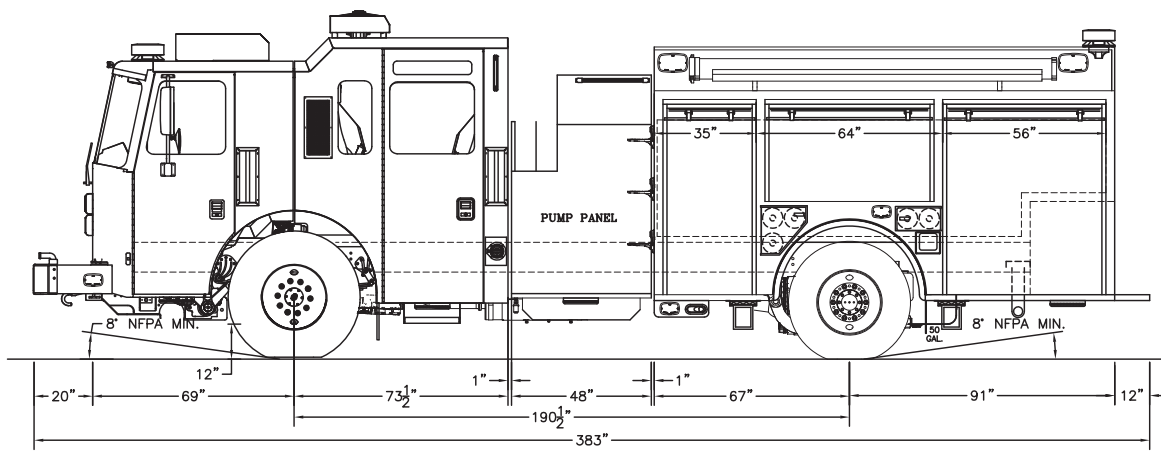
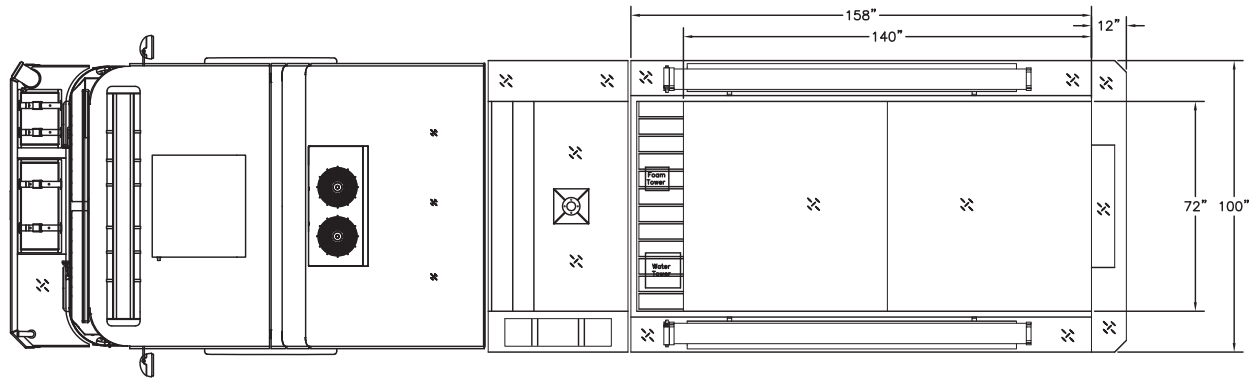
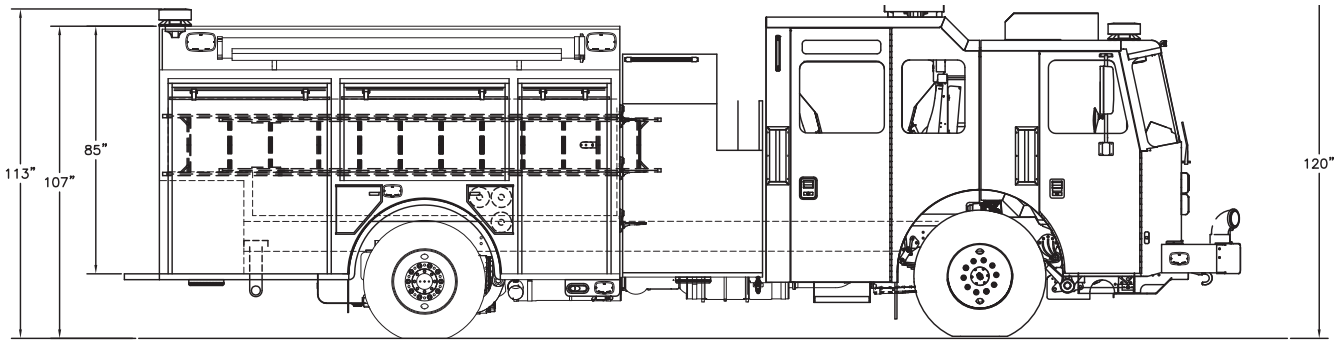

ONE INDUSTRIAL COMPLEX • NESQUEHONING, PA 18240